

# Series 9300 Picture Window Installation Instructions

## Installation Requires Knowledge of :

- Applicable Federal, State, Local Codes and Regulations.
- An Understanding of the Fundamentals of Residential Construction.
- A Working Knowledge of the Tools, Equipment and Methods Required for Installation.
- A Familiarity with Caulking, Sealing Procedures and Glass Handling Procedures.

The Installation covered here REQUIRES the following OPTIONAL items supplied by IWC;

Sill Plate  
Exterior Trims  
Interior Trims

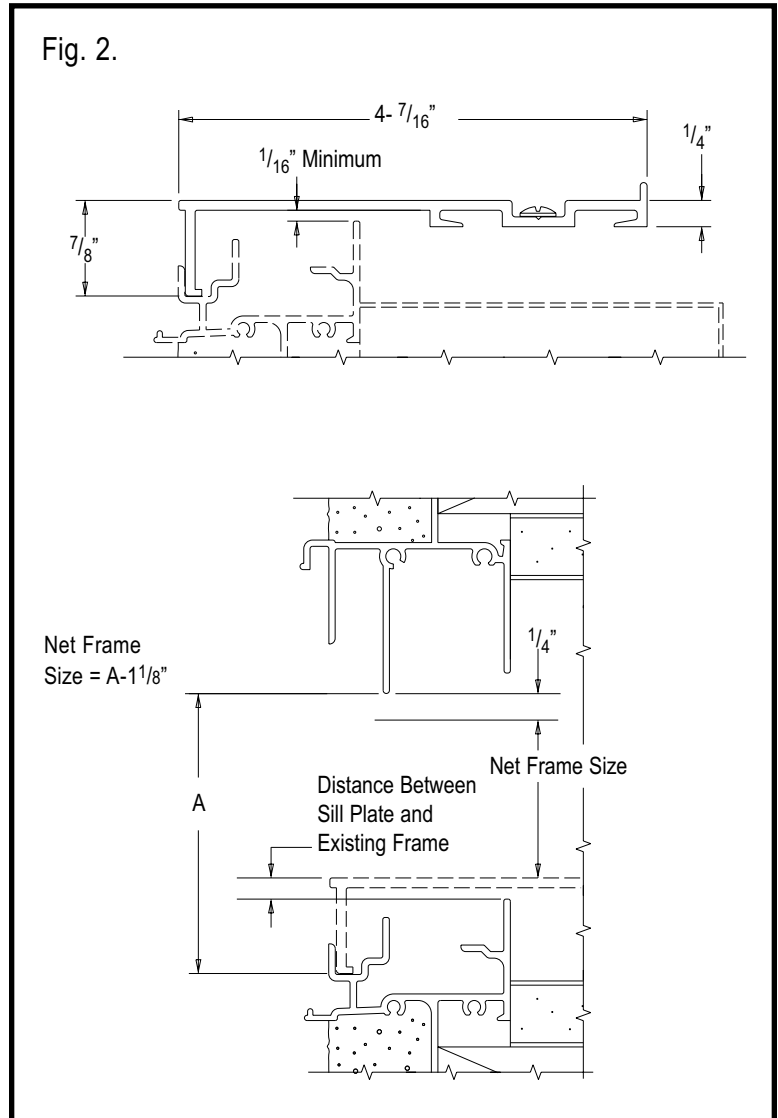
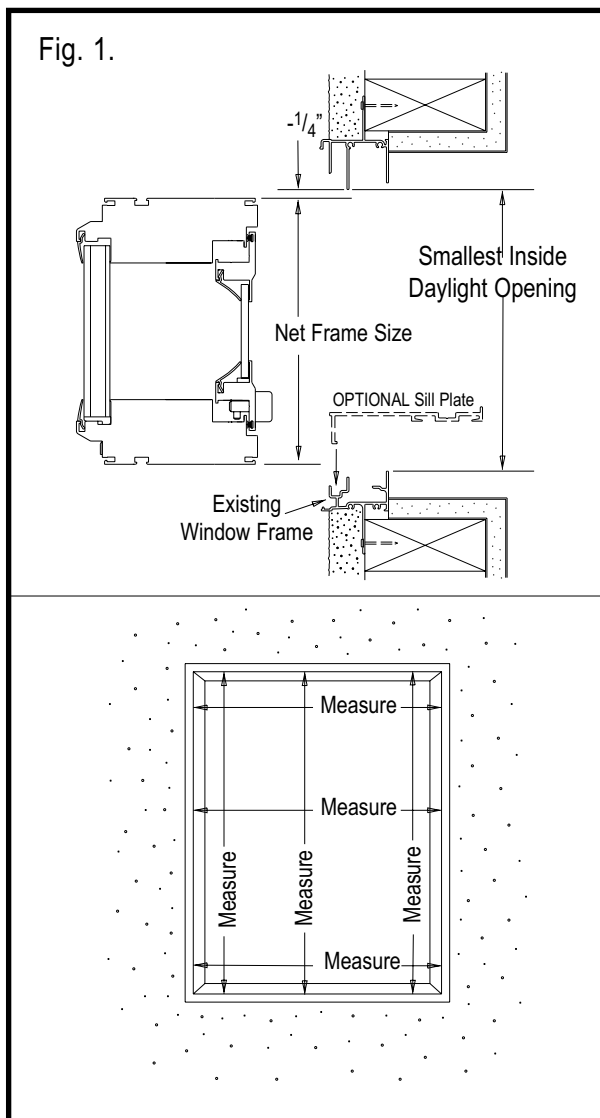

## 1. Measuring Window Opening

A. Measure the opening in your existing window. The narrowest measurements in your window opening, excluding the fixed and sash panels, will be the “daylight opening”. Measure existing daylight opening at the ends and the center. See Fig. 1. Deduct 1/4” from both the width and height of the daylight opening dimensions. A deduction for the distance between the top of the Sill Plate and the tallest wall on the existing sill is also needed to determine the “net frame size”. See Fig. 2. Consider the best location for installing the Sill Plate in the existing sill and then take your measurements.

## 2. Sill Plate Installation

A. Sill Plate should be cut to fit over existing sill and touch both existing jambs.

B. Horse Shoe shims or equal, are needed to support the Sill Plate at installation screw locations. Make sure Sill Plate is straight and level prior to fastening. Screws should be no more than 18” apart on center, with corner screws approximately 6” from jambs. See Fig. 3. Use #8 x 2” Phillips sheet metal screws. Length of screw may vary per job condition. Screws must be long enough to secure Sill Plate to existing wood sill. Anchor the exterior leg of the Sill Plate to the existing sill with #6 x 1/4” Phillips flat head sheet metal screws. Seal screw heads with an appropriate sealant after installing.

## 3. Frame Installation

A. Slide the new frame into the opening. See Fig. 4. Center frame between existing jambs and use shims to straighten and square frame. Wood filler blocks may be used to fill gaps between new and existing frames, but leave a small gap at the head for deflection. Measure frame diagonally across the corners to check for squareness. Adjust if needed.

B. This picture window comes with an interior sash that allows access for internal cleaning. The sash must be in the open position in order to install the window. An L shape janitor’s key should have come with the window for operating the locks on the interior sash. With the long end of the key, turn one lock counter-clock wise to unlock it. See Fig. 5. The lock is spring loaded, so a little pressure while turning is needed. Now, take the short end, the end with the two tabs, and unlock the second one. The key will remain in the lock and can be used as a handle for pulling the sash away.

Fig. 3.

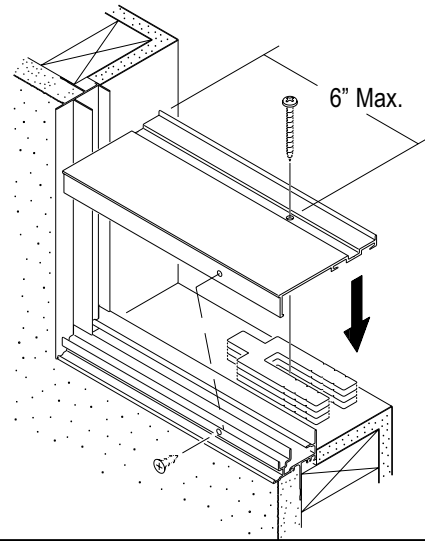

Fig. 4.

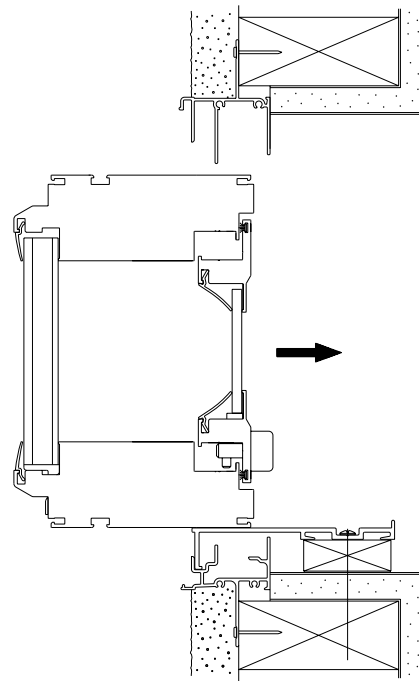
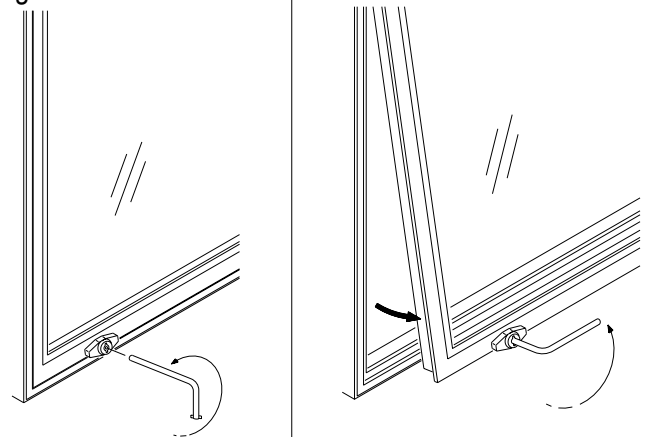
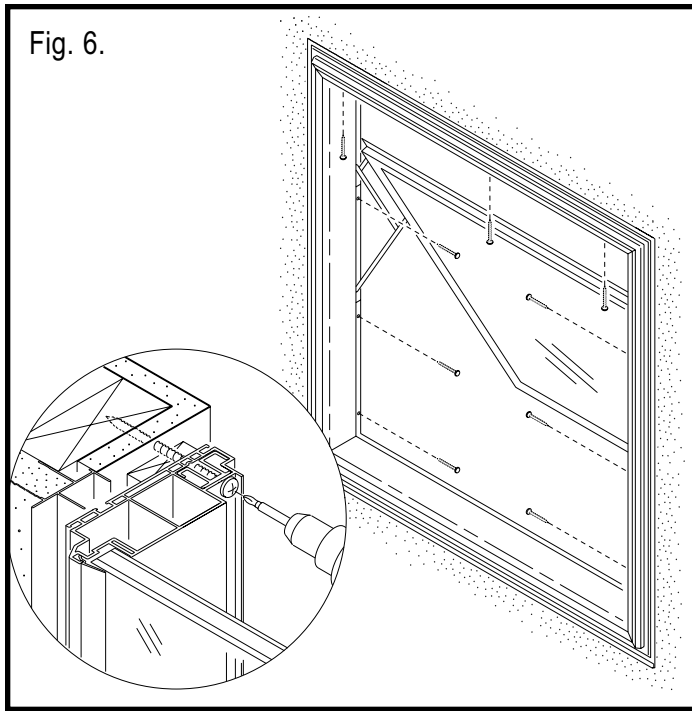

Fig. 5.



# Cont.

# 3



C. With the sash fully extended, install the #8 x 1 1/2" Phillips sheet metal screws in the interior sash channel at head and jambs. See Fig. 6. An installation screw will have to be installed through the hinge mechanism. Back out the center screw in the hinge and replace it with an installation screw. See Fig. 7. Make sure screw head does not interfere with hinge operation. Screws must be long enough to secure new frame to existing wood frame. Screws should be no more than 18" apart on center with corner screws approximately 6" from end. Care should be taken not to over tighten screws, this would avoid warping. Leave a 1/4" gap at the head for deflection between the frames.

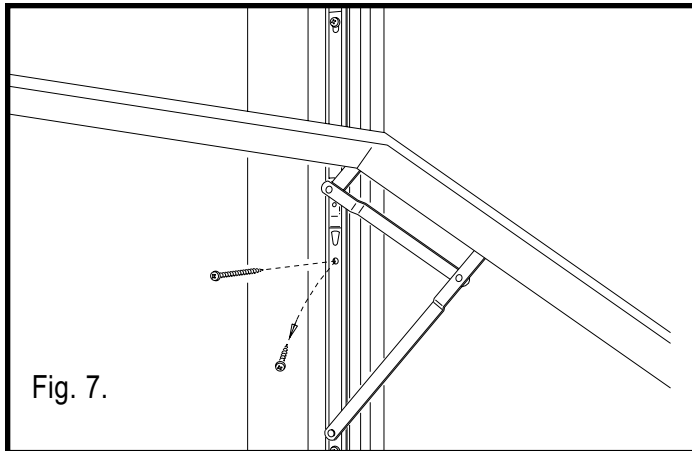

#### 4. Exterior Trim Installation

# 4

A. An optional flat trim material is available to finish off the exterior look. The trim material will be sealed with an appropriate sealant and snapped into the gap that follows the perimeter of the frame. See Fig. 8. Measure the pieces to the frame and with a sharp knife or a heavy scissor, make a 45° cut for a miter fit. Care should be taken not to over cut trim. See Fig. 9.

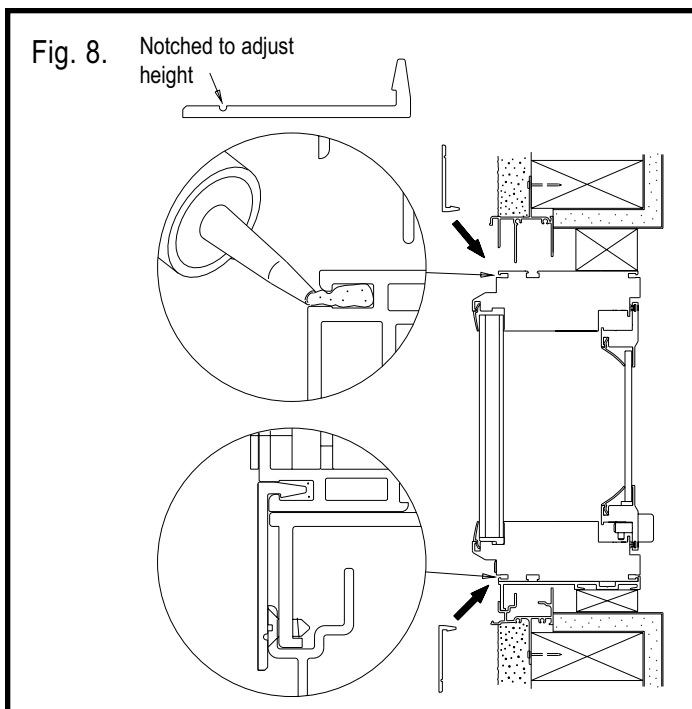

B. Use a recommended sealant for the type of job and materials being used to apply a continuous bead of sealant around the outer edge of the trim you just installed. See Fig. 10.

#### 5. Interior Trim Installation

# 5

A. An optional flat vinyl interior trim is available for concealing the gap between the existing frame and the newly installed window. The trim is applied to the new frame with a double face tape. See Fig. 11. Measure and cut trim to fit. It is your option to use this trim or you may want to use a more decorative wood trim.

Fig. 9.

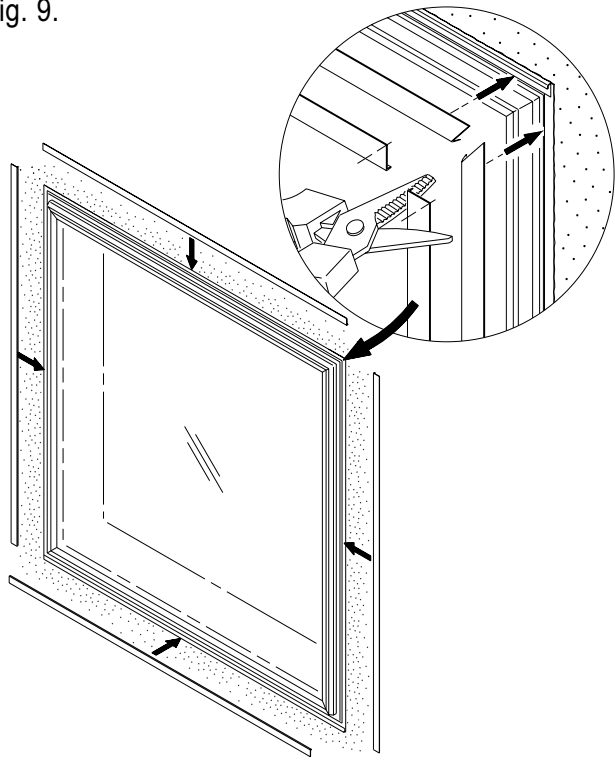

Fig. 11.

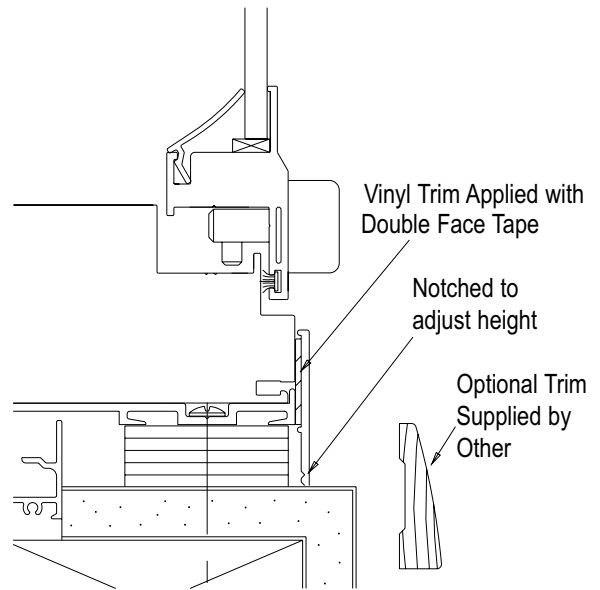
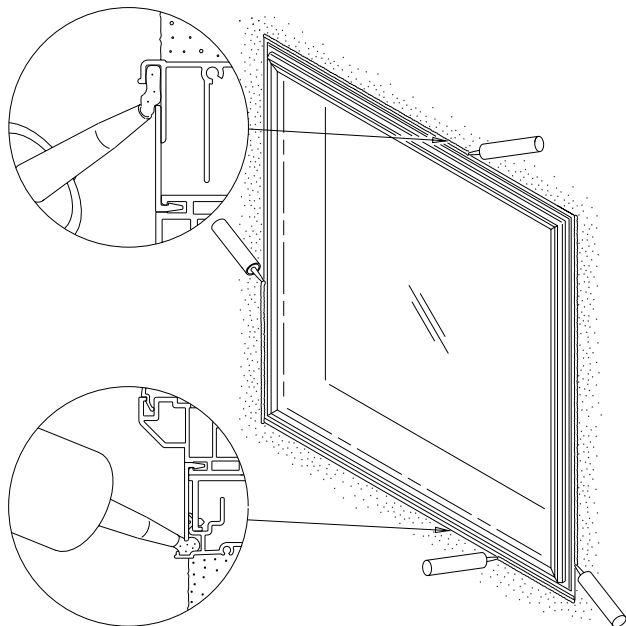

Fig. 10.



- Wood trim, plant-ons, and pot shelves all require special precautions. When necessary under these conditions use metal flashing to prevent paper flashing from tearing. Use metal flashing on any horizontal surfaces where water may not drain.
- Seal all holes in the building paper including those caused by staples or nails.
- Interfaces between our products, flashing and the building's weather resistive barrier must be sealed with a sealant recommended for this application. We cannot recommend a particular type or manufacturer of sealant.
- Holes drilled for alarms may not be placed on sills or heads and must be sealed.
- Extreme weather conditions may cause water intrusion into your home and subsequent water damage.
- Consult a licensed engineer for an appropriated rating for expected local weather conditions.

SEMI-YEARLY MAINTENANCE

- Improperly maintained products will reduced the performance of any window or door. The sills and weeps must be cleaned regularly to allow for drainage. Water in the sill during a rainstorm is normal.
- Weatherstrip should be cleaned and fluffed on a regular basis. Wearing of the wool pile is normal. Wool pile should be replaced if gaps between the weatherstrip and frame appear.
- Harsh abrasive cleaners should never be used on frames or glass surface.

PLEASE KEEP THESE INSTRUCTIONS IN YOUR HOMEOWNER'S PACKET.

Visit Our Website @ [www.intlwindow.com](http://www.intlwindow.com)

International Window Corporation

5625 Firestone Blvd.,  
South Gate, CA 90280  
1-800-477-3391  
Fax 562-928-3492

International Window - Northern California

30526 San Antonio Street,  
Hayward, CA 94544  
510-487-1122  
Fax 510-471-9387

