

Imperial Series

Series 6900/6800 Family of Inside Sliding Patio Doors - Installation Instructions

Installation Requires Knowledge of:

- Applicable Federal, State, Local Codes and Regulations.
- An Understanding of the Fundamentals of Residential Construction.
- A Working Knowledge of the Tools, Equipment and Methods Required for Installation.
- A Familiarity with Caulking, Sealing Procedures and Glass Handling Procedures.



Tools Required

- Hammer
- Power drill
- .171 Dia. drill bit
- Utility knife
- Putty knife
- Caulking gun
- Measuring tape
- Carpenter's square
- Phillips head screwdriver
- Level (6' recommended)
- Shim material
- Caulking (One that's appropriate for your job)
- Locking pliers

Before you start: Read instructions thoroughly and double check the parts lists to make sure all necessary parts are present.

Flashing and/or an appropriate method of sealing shall be designed as a part of an overall weather resistive barrier system. It is not the responsibility of the door manufacturer to design or recommend a flashing system appropriate to each job condition. Responsibility for protecting any flashing material from damage caused by weather, other trades or vandalism and properly integrating the flashing system into the weather resistive barrier for the entire building will be the responsibility of the general contractor or his designated agent.

1. Measuring Window Openings

Check your opening for plumb and square. Check floor for flatness. Correct any problems with the rough opening or floor flatness before proceeding with the installation.

Measure rough opening at the ends and the center. See Fig. 1. Opening should read 1/2" larger than the actual door height and width. With new construction, trimmer studs on each side of the opening should remain loose until the door frame is installed.

2. Frame Assembly

Before assembling the frame, it is very important to use the recommended sealant for your job. Assemble frame by applying a "Small Joint Sealer" to all contact surfaces of the corner joints prior to assembly, see Fig. 2. While the sealant is wet, align the screw holes in the jamb with the slotted ones on the head or sill. Fasten joint with #8 X 5/8" Ph. Pan Hd SMS. For best results, do one corner at a time. After the frame is assembled, run a bead of sealer along both sides (inside and out) of each corner joint. See Fig. 3. It is important that the corner joints are fully sealed to prevent water leakage. Seal over the screw heads with an appropriate sealant.

3. Preparing the Sill

A sill pan is recommended for door installations. Sill pan flashing is used to ensure that incidental water that penetrates the building envelope will be collected and allowed to drain.

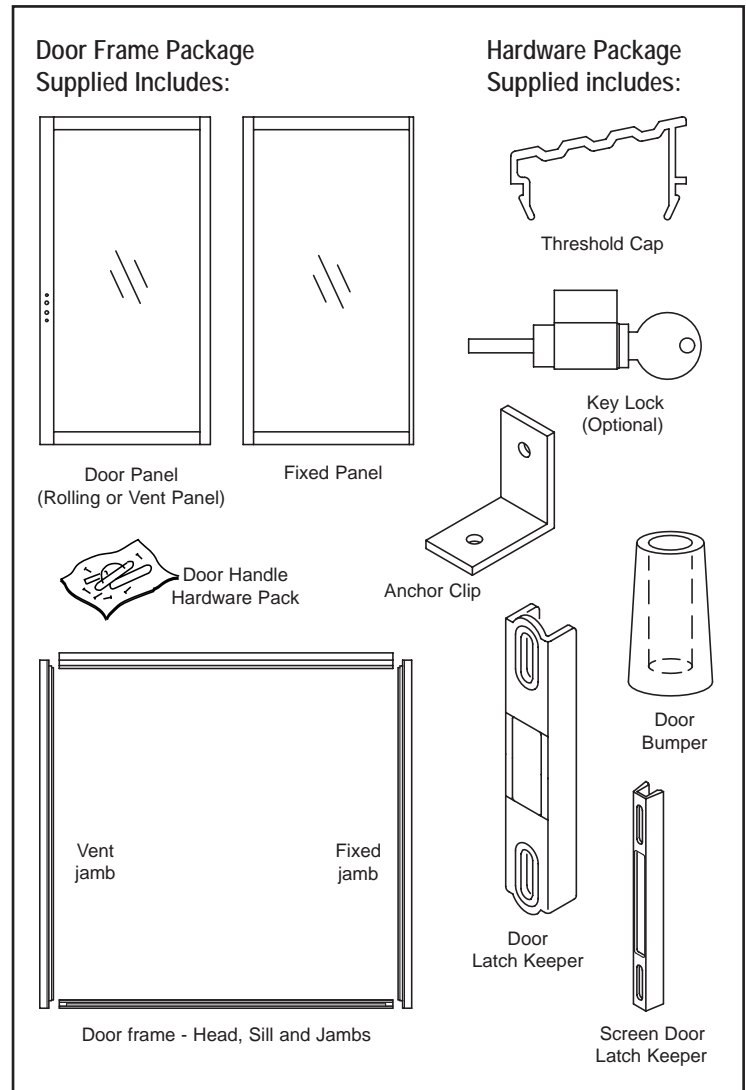

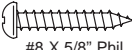
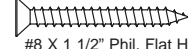
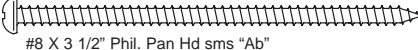
QUANTITY	DESCRIPTION	USAGE
4 Each	 #8 X 3/8" Phil. Truss Hd sms "Ab"	Anchor Clips
8 Each	 #8 X 5/8" Phil. Pan Hd sms "Ab"	Frame Assembly
22 Each	 #8 X 1 1/2" Phil. Flat Hd sms "Ab"	Installation
2 Each	 #8 X 3 1/2" Phil. Pan Hd sms "Ab"	Door Latch Keeper

Note: Be sure to remove all Packing Material including the wood support beneath the sill.

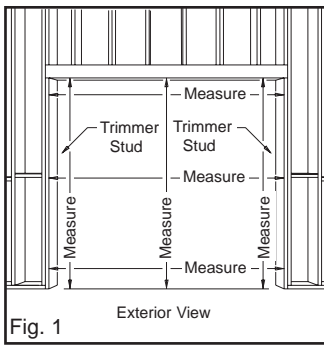

Fig. 1

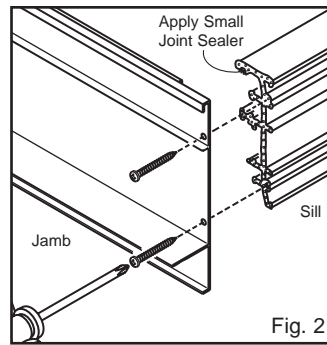

Fig. 2

A sill pan is a rigid piece of flashing with an interior wall and side end dams. The sill pan prevent water from flowing into the wall or interior finishes. The sill pan flashing material and fasteners are provided by others. Sill pan must be formed to fit around the door frame at the sill. The flashing should also fit the sill condition, sloping if needed to the exterior, see Fig. 5.

4. Installing the Sill Pan

After fabricating the sill pan, dry fit the pan in the sill opening to check for size and fit. The sill condition must be level. If not level, use shims under the sill pan to correct this. Dry fit the door frame on the sill pan also for size and fit, see Fig. 4. Center frame in rough opening. If frame sill is not level, shim between frame and sill pan. Also check the rest of the frame for square and plumb. Installation screws will be installed through the center channel in the sill, see Fig 5. If holes have not been pre drilled in the sill, determine the number and location of fasteners to be used and drill them. The sill needs a minimum of 3 fasteners, based on a maximum of 16" apart, on center. Installation holes should have a .171 diameter, big enough for a #8 screw. If door is being installed on a concrete floor, mark the location of the installation holes on the sill pan below for reference. Remove door frame from opening to expose the sill pan. Pre-drill two pilot holes in each end dam for fastening the sill pan to the frame studs in the rough opening, see Fig. 6.

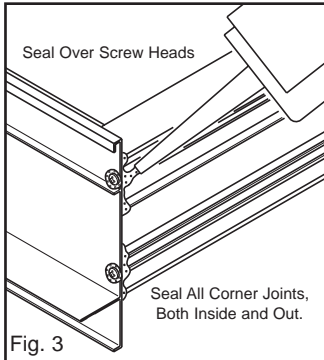

Fig. 3

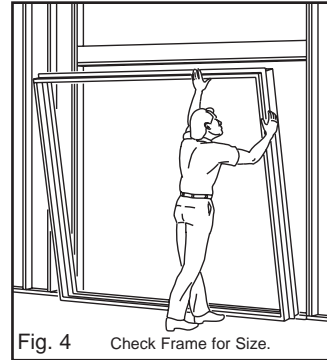

Fig. 4 Check Frame for Size.

For concrete floor installation, pre-drill installation holes in the sill pan. Install masonry screw anchors at this point.

Determine the proper sealant to use for the materials and building condition you are working with. Remove the sill pan and lay a sealant bed at both corners of the sill opening where the floor and framing studs meet, see Fig. 5. Apply sealant up both studs about 6 inches. Then run a generous bead of sealant between the two studs, along the Interior edge of the sill where the sill pan will set. Apply a 3/8" diameter bead of sealant to the exterior edge of the sill. Leave two 1" gaps, approximately 6" from each jamb. These gap allow for any water drainage. Replace sill pan in the opening, on top of sealant and shims. Line up installation holes and apply even pressure to the pan to ensure contact. Check pan for straight and level. Secure sill pan to opening with fasteners through the end dams. Seal over the fastener heads and all joints between the sill pan and the wall condition, see Fig. 6.

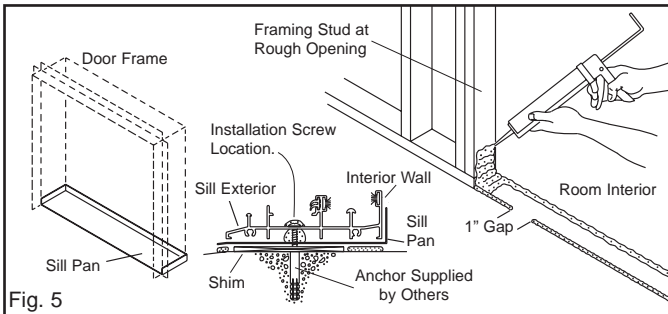

Fig. 5

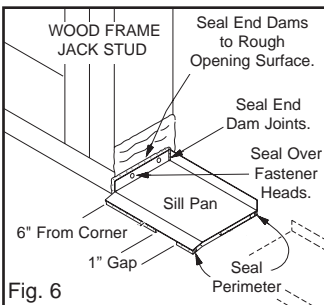

Fig. 6

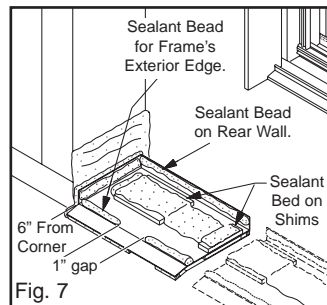

Fig. 7

5. Installing the Door Frame

With sill pan secured, apply a generous, full length, continuous bead of sealant to the rear, upright wall of the sill pan. This bead will make contact with the door frame to create an air seal along the back side of the frame and sill condition. Apply a 3/8" diameter bead of sealant to the top of the sill pan where the exterior edge of the door frame will come in contact. Leave two 1" gaps, approximately 6" from each jamb for drainage, see Fig. 7.

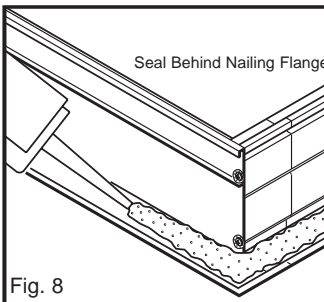
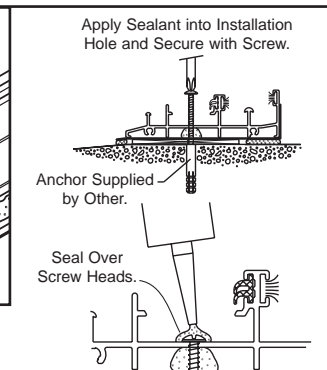
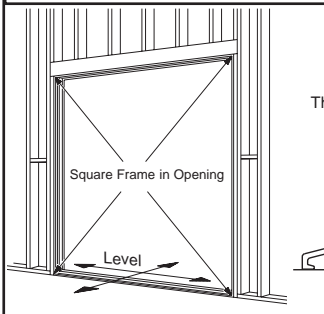

Fig. 8



Threshold Cap



Square Frame in Opening

Level

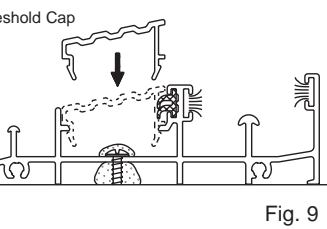

Fig. 9

With an appropriate sealant, apply a generous bead to the back side of the nailing flange of the frame, see Fig. 8. Set the door frame into the rough opening and align installation holes in the sill. Check frame for level, square and plumb and shim where needed. Secure sill with #8 X 1 1/2" Phil. Flat head screws. Square the frame by measuring diagonally across the corners and adjusting the frame until the measurements are equal, see Fig. 9. Secure one of the upper jamb corners first with a #8 X 1 1/2" Phil. Flat head screw. Check for level and plumb again. With the remaining installation screws, determine the location of the other fasteners in the head and jambs of the frame. The Vent Panel Bumper will be installed in the center of the fixed jamb with one of the installation screws, see Fig. 10. Position shims as close to installation screws as possible. Secure the remainder of the frame. When installing the fasteners to the head portion of the frame, caution should be taken not to over tighten and distort the frame. Leave about a 1/2" space between frame and rough opening for deflection. Once the frame is secure, apply sealant over the screw heads on sill.

6. Installing the Fixed Panel

The fixed panel is installed from the exterior. As per your door order, determine what side of the frame will house the fixed panel, the stationary panel. Hold the fixed panel with the interlock in the center of the door opening facing inward. See exploded view of door for orientation.

Lift the panel up into the center channel in the head of the frame and lower it into the sill's channel, see Fig. 11. Trim the excess material from the interlock bug strip so that it fits tightly between the head and sill, see Fig. 12. Push the panel into the fixed jamb as far as it will go, see Fig. 13.

7. Installing the Rolling Panel

Install the rolling panel or vent panel from the interior. With the weather strip side of the frame opening facing to the outside, stand in the middle of the frame opening and lift the panel into the channel closest to you in the frame's head, see Fig. 14. Swing the bottom in and tuck the panel down into the sill channel. If panel does not clear sill, the rollers may be dangling below the bottom edge of the panel. Roller wheels must be tucked into the bottom rail of the panel to clear the sill. To adjust rollers, turn the adjustment screw through the holes at the bottom of both ends of the panel with a Phillips head screwdriver, see Fig. 15. Turn counter clockwise to retract the wheels. When panel is installed, make sure rollers are resting on the roller track.

8. Door Handle and Latch Keeper Installation

The vent panel is shipped without handles and have to be installed at the job site. In the hardware pack that's included, the large "C" shape handle goes on the interior side of the door. Start by inserting the flat tab on the thumb turn into the hub slot of the mortise lock already installed in the lead stile. Insert the anti knock out plug into the exterior handle, see Fig. 16. This plug is used if a lock cylinder is not installed in the handle. Attach both handles to the lead stile with two ring gaskets and two #8-32 X 2" Phillips oval head screws.

Install the latch keeper to the vent jamb with two #8 X 3 1/2" Phillips pan head screws, see Fig. 17. Use shims between frame and rough opening at latch keeper location. The elongated holes on the keeper allows for strike adjustment. Do not tighten screws completely. Close the door and use the thumb turn to extend the strike. Adjust the latch keeper up or down to the proper height for full hook engagement. Tighten screws on the keeper to maintain correct height.

Check the panels for proper spacing in the frame by pushing the vent panel into the vent jamb. Both panels should penetrate their corresponding jambs and the interlock, where the panels meet, should be fully engaged.

Adjust vent panel for operating ease by turning the roller adjustment screws clockwise a couple of turns until panel moves freely. Close the door and check the alignment of the panel with the frame jamb. Both should meet evenly at the head and sill, if not, adjust rollers up or down to align panel.

Note: Relieve pressure on roller cam by lifting the panel while turning the adjustment screw.

With the panels properly spaced in the frame, secure the fixed panel by slipping two "L" clips into the interlock at the sill and head of the frame, see Fig. 18. Fasten the "L" clip to the interlock and sill with #8 X 3/8" Phillips Truss head screws, see Fig. 19. Use the existing hole in the interlock to line up the hole on the clip. Drill a pilot hole in the sill using the hole in the clip. Seal screw heads with sealant. Repeat the procedure at the head section. Now, install the threshold cap into the center channel of the sill along side the fixed panel, see Fig. 20. The length may have to be shorten to fit your frame. The cap should slope to the exterior of the door. Also, the threshold cap will have to be notched slightly to accommodate the "L" clip at the interlock. Notch the leg tips off 1 1/2" on the side by the interlock, see Fig. 21. When installing the cap, start at the interlock and work down towards the fixed jamb. With an appropriate sealant, seal the fixed panel to the frame from the interior, see Fig. 22. Run a perimeter bead along the head, jamb and sill. Seal the joint between the threshold cap, jamb and interlock.

9. Screen Door Installation (6800 Roll Form Panel Not Shown)

Hold the screen door with the screen spline to the outside. Lift the panel into the screen channel in the head of the door frame. Roller wheels must ride on track in the head to operate properly, see Fig. 23. Swing bottom of screen panel onto sill track. Push bottom rollers up into the frame and guide them onto the sill's screen track. You may need a

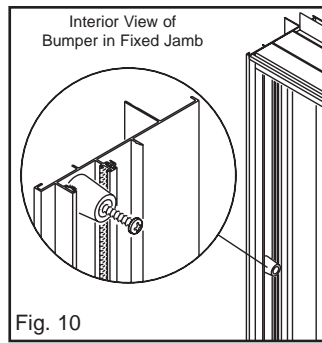

Fig. 10

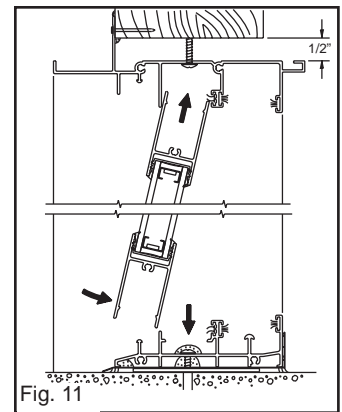

Fig. 11

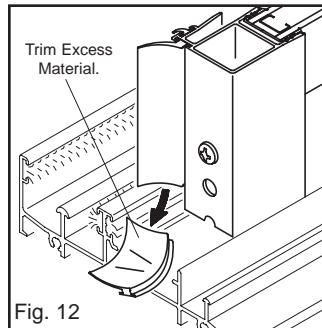

Fig. 12

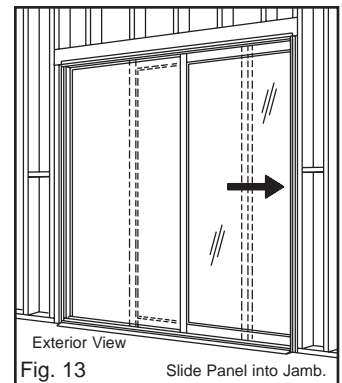

Fig. 13

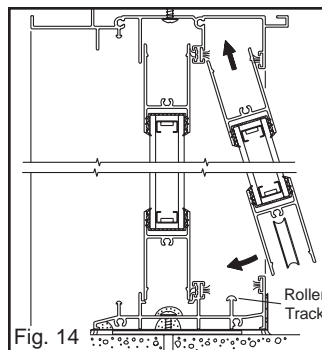

Fig. 14

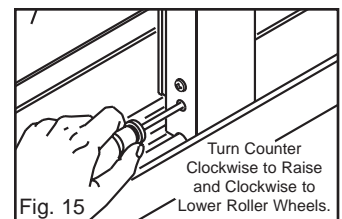

Fig. 15

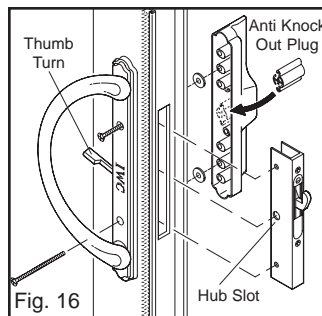

Fig. 16

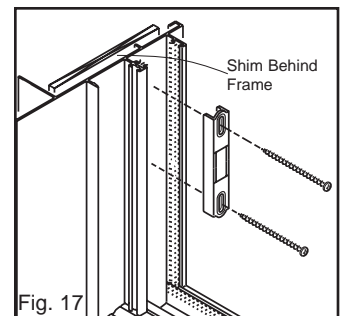

Fig. 17

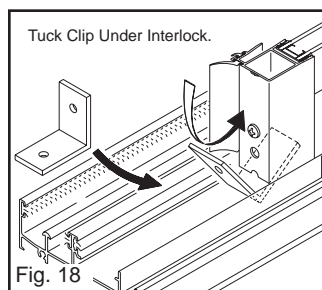

Fig. 18

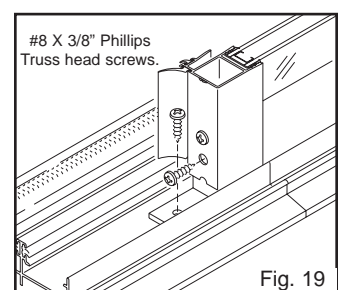

Fig. 19

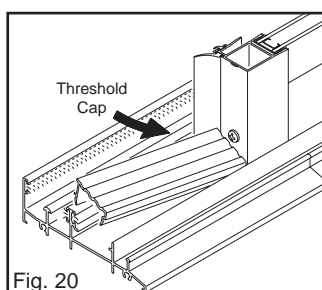

Fig. 20

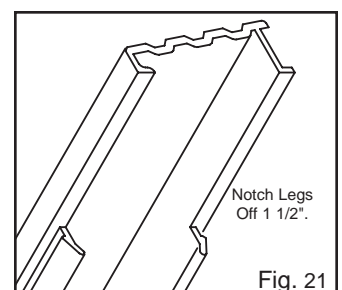
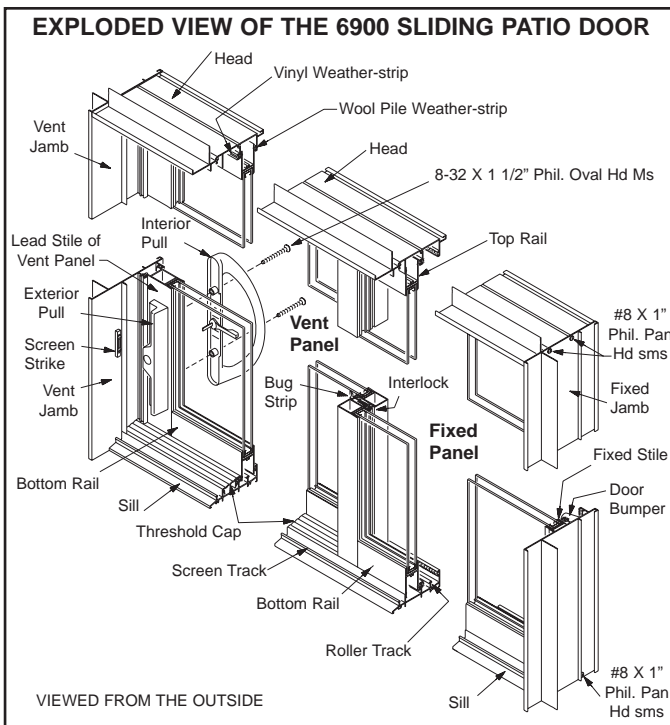
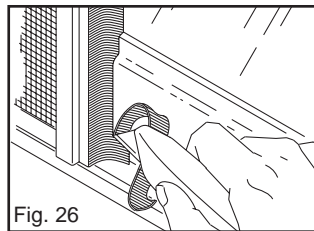
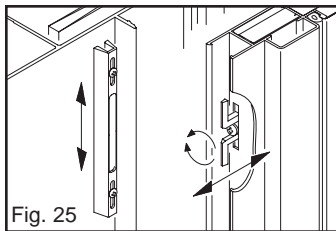
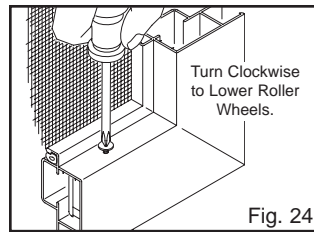
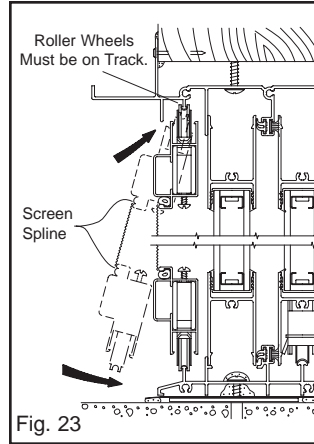
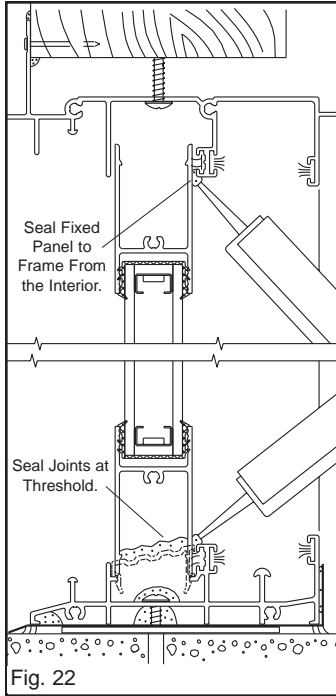

Fig. 21

flat screw driver or putty knife for this. Adjust bottom rollers so screen panel is vertically parallel with door frame. The roller can be adjusted by taking a Phillips screw driver and turning the screws through the holes in the frame, see Fig. 24. Turning the screws clockwise will extend the rollers. Don't over tighten, screen door must operate smoothly.

10. Screen Door Strike (6800 Screen Door Strike Not Shown)

Install the screen door strike to the vent jamb with one #6 X 1/2" Phillip pan head Tek screw, see Fig. 25. Adjust the strike, up or down, to determine the correct height to engage the screen door latch. Once latch and strike operate smoothly, secure strike with a second Tek screw.



11. Trimming the Bug Seal

Trim the Bug Seal vinyl on the screen panel for a better fit. Use a sharp utility knife or razor blade to trim the excess vinyl away from the fixed panel's top and bottom rails only. Follow the contours along the top and bottom rail, see Fig. 26. Care should be taken not to scratch any painted surface with the blade.

- Wood trim, plant-ons, and pot shelves all require special precautions. When necessary under these conditions use metal flashing. Use metal flashing on any surfaces where water may not drain promptly.
- Seal all holes in the building paper including those caused by staples or nails.
- Interfaces between our products, flashing and the building's weather resistive barrier must be sealed with a sealant recommended for this application. We cannot recommend a particular type or manufacturer of sealant.
- Mull windows require special treatment. Please consult instructions for your mull conditions.
- Holes drilled for alarms may not be placed on sills or heads and must be sealed.
- Extreme weather conditions may cause water intrusion into your home and subsequent water damage. Consult a licensed engineer for an appropriate rating for expected local weather conditions.
- Do not apply film or tints to the surface of the glass. These products can cause insulated unit failure.

SEMI-ANNUAL MAINTENANCE

- Improperly maintained products will reduced the performance of any window or door. The sills and weeps must be cleaned regularly to allow for drainage. Water in the sill during a rainstorm is normal.
- Weather-strip should be cleaned and fluffed on a regular basis. Wearing of the wool pile is normal. Wool pile should be replaced if gaps between the weather-strip and frame appear.
- Harsh abrasive cleaners should never be used on frames or glass surface.
- If products are within 10 miles of the coast, metal surfaces should be cleaned with a fresh water rinse every one to three months. Car wax on the surface will provide some protection. Anodized or painted surfaces will help prolong the life and enhance appearance. Clean and lubricate hardware components with corrosion resistant spray or lubricant monthly to ensure proper performance. Silicone lubricant spray can be used on all operable components.

PLEASE KEEP THESE INSTRUCTIONS IN YOUR HOME OWNER'S PACKET.

I have read the above instructions and understand the manufacturer's recommendations.

(Installer's signature)

6900INSTR0609

International Window Corporation
5625 Firestone Blvd.
South Gate, CA 90280
1-800-477-3391
Fax 562-928-3492

International Window-Northern California
30526 San Antonio Street
Hayward, CA 94544
510-487-1122
Fax 510-471-9387

International Window-Arizona, INC.
2500 East Chambers Street
Phoenix, AZ 85040
602-232-2500
Fax 602-268-1100



Visit Our Web Site @ www.intlwindow.com